

CSNV1500 SERIES

005998
Issue 5

Closed Loop Current Sensors

DESCRIPTION

The CSNV1500 Series are Hall-effect current sensors that use Honeywell's patented technology to bring the enhanced combination of performance and reliability. The sensors are non-intrusive and electrically isolated from the monitored circuit. This ensures a simple and reliable structure without loss of power to the monitored circuit. The CSNV1500 Series are rated for a primary current measurement range of ± 1500 A dc. They are calibrated and temperature compensated for improved accuracy using multi-point temperature characterization.

DIAGNOSTIC FUNCTIONALITY/ CAN OUTPUT

The CAN output of the CSNV1500 Series provides fault detection and communication capability. Also, the digital CAN communication is very immune to electrical interference. Examples of sensor and host system faults are as follows:

- Sensor fault
- Supply voltage over range
- Supply voltage under range

CUSTOMIZATION

The CSNV1500 Series may be customized to meet application needs. Solutions may be tailored to exact specifications for improved time to market, lower total system costs and enhanced reliability. For technical assistance, we provide global engineering and service support for your needs.

DIFFERENTIATION

- **Accuracy:** Multi-point temperature characterization and calibration for improved accuracy over temperature range
- **Magnetic immunity:** Optimized magnetic circuit allow for high performance in diverse magnetic environments
- **Flexible:** Customizable on-board firmware to meet specific application requirements

VALUE TO CUSTOMERS

- **Accurate:** Designed to enable precise battery state measurement for improved user experience
- **Ease of use:** Magnetic immunity allows for easy integration into different magnetic environments
- **Easy system integration:** CAN communication is transmitted using international road vehicle standard ISO 11898. CAN 2.0A is the default protocol

APPLICATIONS

- Current measurement for battery management systems in electrified vehicles (EV, HEV, PHEV, BEV)
- Current leakage detection and fault isolation in charging systems
- Current measurement in energy storage systems
- Fault detection in heavy industrial equipment



FEATURES

- Active current sensing using Hall-effect technology
- Utilizes proprietary Honeywell technology for temperature compensation
- High accuracy and low temperature drift
- Operating temperature of -40°C to 85°C [-40°F to 185°F]
- Digital output: CAN bus output with selectable ID
- Internal diagnostic function
- Different configuration options: Mounting type, baud rate, CAN ID
- CE and UKCA certification; REACH and RoHS compliant

PORTFOLIO

Honeywell offers a variety of current sensors for potential use in many applications. To view the entire product portfolio, [click here](#).

Honeywell

CLOSED LOOP CURRENT SENSORS

CSNV1500 SERIES

TABLE 1. ABSOLUTE MAXIMUM RATINGS (not operating)

Characteristic	Symbol	Unit	Parameter	Condition
Load dump over voltage	V_S	V	32	400 mSec
Over voltage	V_S	V	24	10 min
Reverse polarity	V_S	V	20	continuous
Reverse polarity	V_S	V	-24	10 min
Supply voltage:				
minimum	V_S	V	6	—
maximum		V	18	—
CAN operation:				
supply voltage under range alarm, no measurement	V_S	V	6 to 7	CAN continuous
supply voltage over range alarm, no measurement		V	18 to 24	CAN continuous
Insulation resistance	IR	M Ω	500	500 V DC at 1 min
Creepage distance	D_{CP}	mm	7,5	—
Clearance	D_{CL}	mm	7	—
RMS voltage:		kV		
ac isolation voltage	—		2.5	50 Hz, 1 min
dc isolation voltage			2.5	1 min

TABLE 2. OPERATING SPECIFICATIONS IN NOMINAL RANGE (I_{PN})

Characteristic	Symbol	Unit	Specification			Condition
			Min.	Typ.	Max.	
Primary current, nominal measuring range (dc)	I_{PN}	A	-1500	—	1500	full temperature range
Supply voltage	V_S	V	7	12	18	full accuracy
Supply voltage hysteresis:						
maximum	V_{UP}	V	—	18.1	—	when V_S increases
	V_{UP}	V	—	17.7	—	when V_S decreases
minimum	V_{LOW}	V	—	7.3	—	when V_S increases
	V_{LOW}	V	—	6.9	—	when V_S decreases
Current consumption:						
at $I_p = 0$ A	I_{SUPPLY}	mA	—	21	30	$V_S = 12$ V, $T = 25^\circ$ C
at $I_p \neq 0$ A	I_{SUPPLY}	mA	—	160	200	$V_S = 12$ V, $T = 25^\circ$ C
Ambient operating temperature	T_a	$^\circ$ C	-40	—	85	temperature range with accuracy guaranteed, ± 3 sigma
Error at $I_p = -10$ A to $+10$ A (offset current)	I_{OS}	A	-0.1	—	0.1	3 sigma, $T = 40^\circ$ C to 85° C
Total accuracy at 10 A $< I_p \leq 1500$ A	X_G	—	—	$\pm 1\%$	—	3 sigma, $T = 40^\circ$ C to 85° C

TABLE 3. MECHANICAL SPECIFICATIONS

Characteristic	Parameter
Housing material	PA66+GF25 (UL 94V - 0)
Mounting screws	M5, torque max. 3.5 N m The installation bracket should have a flatness tolerance of $\leq 0,2$ mm. The size tolerances of the installation bracket and nut, as well as the use of installation tools and fixtures, have an impact on the maximum installation torque of the product. If there are any relevant design or process changes, it is advisable to implement them after verification.
Mating electrical connector	TE MPN 1473672-1
Weight	168 g ± 5 g

CLOSED LOOP CURRENT SENSORS

CSNV1500 SERIES

TABLE 4. CANBUS SPECIFICATIONS^{1,2,3,4}

Message Description	Can ID	Data Length	Message Launch Type	Signal Description	Signal Name	Start Bit	Length
Output current I_p (mA)	See Figure 2	8 bytes	Cyclic transmitted message 10 mSec cycle	I_p value: 80000000h = 0 mA 7FFFFFFFh = -1 mA 80000001h = 1 mA	IP_VALUE	24	32
				Error indication (1 bit) 0 = normal 1 = failure	ERROR_INDICATION	32	1
				Error information 0x64 when indication = 0	ERROR_INFORMATION	33	7
				Fixed to 0	VACANT_DATA_3BYTES	56	24

¹ CANBUS speed: See Figure 2

² CAN bus protocol: Version 2.0A

³ CAN oscillator tolerance: 0.3125 %

⁴ Byte order: Big endian (Motorola)

TABLE 5. DIAGNOSTIC TROUBLE CODES

Failure mode	I_p Value	Error Indication	Error Information
Flash CRC error	FFFF FFFFh	1	0x40
AFE over range	FFFF FFFFh	1	0x41
AFE error	FFFF FFFFh	1	0x42
Internal LUT error	FFFF FFFFh	1	0x44
Power minimum limit	FFFF FFFFh	1	0x46
Power maximum limit	FFFF FFFFh	1	0x47

Figure 1. I_p Positive Primary Current Direction (Polarity)

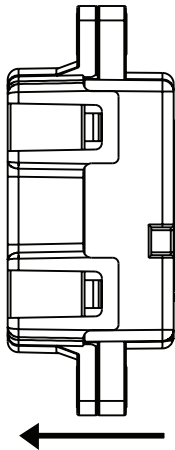

CLOSED LOOP CURRENT SENSORS

CSNV1500 SERIES

TABLE 6. ORDER GUIDE

Catalog listing	Description
CSNV1500N-124	CSNV1500 Series Hall-based current sensor, 1500 A, through-hole mounting with stainless steel bushing, MCU1, 250k baud rate, 3C4 CAN ID
CSNV1500N-125	CSNV1500 Series Hall-based current sensor, 1500 A, through-hole mounting with stainless steel bushing, MCU1, 250k baud rate, 3C5 CAN ID
CSNV1500N-126	CSNV1500 Series Hall-based current sensor, 1500 A, through-hole mounting with stainless steel bushing, MCU1, 250k baud rate, 3C6 CAN ID
CSNV1500N-324	CSNV1500 Series Hall-based current sensor, 1500 A, through-hole mounting with stainless steel bushing, MCU2, 250k baud rate, 3C4 CAN ID
CSNV1500N-325	CSNV1500 Series Hall-based current sensor, 1500 A, through-hole mounting with stainless steel bushing, MCU2, 250k baud rate, 3C5 CAN ID
CSNV1500N-326	CSNV1500 Series Hall-based current sensor, 1500 A, through-hole mounting with stainless steel bushing, MCU2, 250k baud rate, 3C6 CAN ID
CSNV1500N-154	CSNV1500 Series Hall-based current sensor, 1500 A, through-hole mounting with stainless steel bushing, MCU1, 500k baud rate, 3C4 CAN ID
CSNV1500N-155	CSNV1500 Series Hall-based current sensor, 1500 A, through-hole mounting with stainless steel bushing, MCU1, 500k baud rate, 3C5 CAN ID
CSNV1500N-156	CSNV1500 Series Hall-based current sensor, 1500 A, through-hole mounting with stainless steel bushing, MCU1, 500k baud rate, 3C6 CAN ID
CSNV1500N-354	CSNV1500 Series Hall-based current sensor, 1500 A, through-hole mounting with stainless steel bushing, MCU2, 500k baud rate, 3C4 CAN ID
CSNV1500N-355	CSNV1500 Series Hall-based current sensor, 1500 A, through-hole mounting with stainless steel bushing, MCU2, 500k baud rate, 3C5 CAN ID
CSNV1500N-356	CSNV1500 Series Hall-based current sensor, 1500 A, through-hole mounting with stainless steel bushing, MCU2, 500k baud rate, 3C6 CAN ID

CLOSED LOOP CURRENT SENSORS CSNV1500 SERIES

Figure 2. Nomenclature

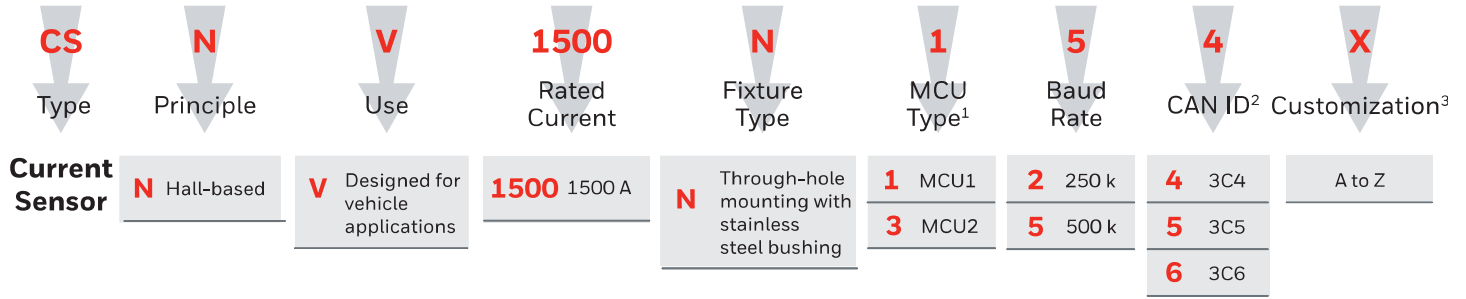

¹The MCU1 version is a drop-in replacement for the MCU2 version. There is no change to product fit, form, or function.

The MCU options improve material supply.

²Custom CAN IDs are available. Contact Honeywell Customer Service for more information.

³Other customizations contact Honeywell Customer Service for more information.

Figure 3. Dimensional Drawings (For reference only: mm)

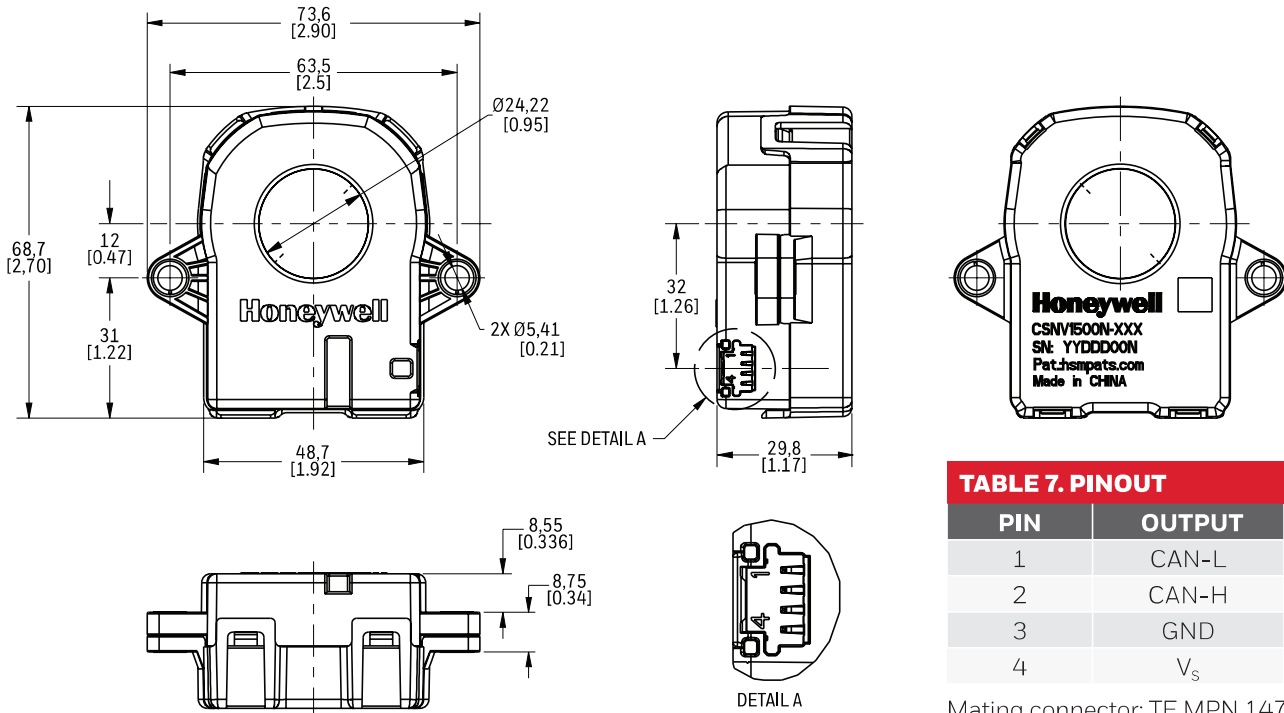

PIN	OUTPUT
1	CAN-L
2	CAN-H
3	GND
4	V _s

Mating connector: TE MPN 1473672-1

Figure 4. Part Marking Details

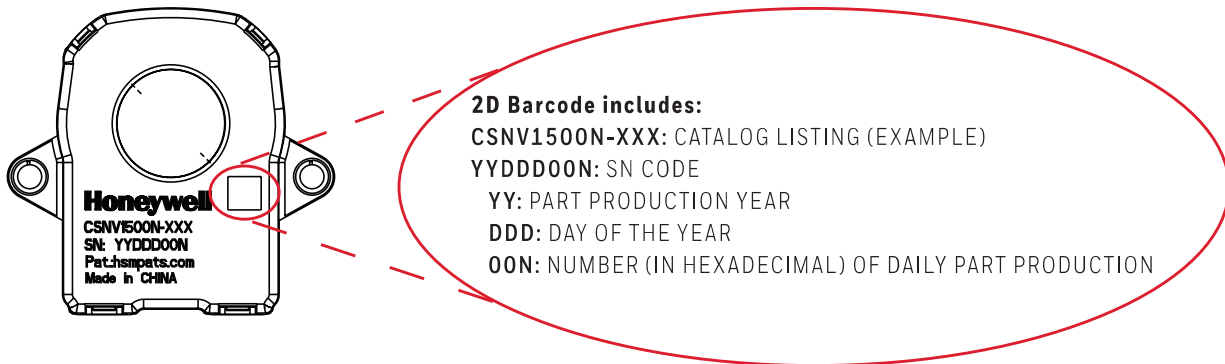

CLOSED LOOP CURRENT SENSORS

CSNV1500 SERIES

TABLE 8. EMC TEST SPECIFICATIONS

Test	Standard	Procedure
CISPR 25 Conducted RF Emissions - Voltage	CISPR25	According to CISPR 25:2008 Commission Form of Testing
CISPR 25 Conducted RF Emissions - Current	CISPR25	According to CISPR 25:2008 Commission Form of Testing
CISPR 25 Radiated Emissions- ALSE method	CISPR25	According to CISPR 25:2008 Commission Form of Testing
Transient Conduction Emission	ISO 7637-2	According to ISO 7637-2
Low Frequency Magnetic Field Emission	SAE J551-5	According to SAE J551-5
Low Frequency Field Interference	ISO 11452-8	According to ISO 11452-8
Bulk Current Injection (BCI) Test	ISO 11452-4	According to ISO 11452-4
Rf Anti-Interference - ALSE Method	ISO 11452-2	According to ISO 11452-2
Transient Disturbances Conducted along Supply Lines	ISO 7637-2	According to ISO 7637-2
Transient Disturbances Conducted along I/O or Sensor Lines	ISO 7637-3	According to ISO 7637-3
Electrostatic Discharge	ISO 10605	Unpowered direct contact discharge: ±8 kV Unpowered air discharge: ±15 kV Powered-up direct contact discharge: ±4 kV Powered-up air discharge: ±10 kV
Portable Transmitter	ISO 11452-9	According to ISO 11452-9
Surge	IEC 61000-4-5	±0.5 kV
Radio Frequency Electromagnetic Field	IEC 61000-4-3	10 V/m (80 MHz to 1 GHz), 3 V/m (1.4 GHz to 2 GHz), 1 V/m (2.0 GHz to 2.7 GHz)
Fast Transients Bursts Susceptibility Test	IEC 61000-4-4	2 kV Power port, 1 kV CAN signal and control port
Radio Frequency Continuous Conducted	IEC 61000-4-6	0.15 MHz to 80 MHz, 3 V 80 % AM (1 kHz)
Radio Frequency Magnetic Field	IEC 61000-4-8	30 A/M
Radiated Disturbance (3M semi-anechoic chamber)	CISPR-11	Group 1, Class A

CLOSED LOOP CURRENT SENSORS

CSNV1500 SERIES

TABLE 9. ENVIRONMENTAL TEST SPECIFICATIONS

Test	Standard	Procedure
Low Temperature Operating Test	ISO16750-4	120 hr, -40°C, Performance test before and after test only at 25°C and V _S nom.
High Temperature Operating Test	ISO16750-4	3000 hr, 85°C, Performance test before and after test only at 25°C and V _S nom.
Thermal Cycle Test	ISO16750-4	120 cycles, one cycle contains -40°C (120 min soak) & 85°C (120 min soak). Transition time = 120 mins. Performance test before and after test only at 25°C and V _S nom.
High Temperature and Humidity Endurance	IEC 60069-2-67	1000 hr, 85°C, 85 % humidity, Performance test before and after test only at 25°C and V _S nom.
Vibration	IEC60068-2-64	5 Hz to 2000 Hz, 20 hr/axis, 3 axis with -40°C/85°C temperature cycle during test. Performance test before and after test only at 25°C and V _S nom.
Mechanical Shock	ISO16750-3	500 m/s, 2, 20 each direction (60 total), half sine pulse. Performance test before and after test only at 25°C and V _S nom.
Package Drop	ISTA-1A	With final packaging, drop in direction at 1 corner, 3 edge, 4 face > total 9 drops, 1 m on concrete floor.
Handling Drop	ISO 16750-3	1st fall of each DUT at a different dimensional axis, 2nd fall with the given DUT at the same dimensional axis but on the opposite side of the housing, from 1 m on concrete floor. Performance test before and after test only at 25°C and V _S nom.
Waterproof and Dust (and other Solid Intrusion)	ISO20653	IP category: 40
Material Flame Grade	UL94	UL94-V0

CLOSED LOOP CURRENT SENSORS

CSNV1500 SERIES

TABLE 10. ELECTRICAL TEST SPECIFICATIONS

Test	Standard	Procedure
Long Time Overvoltage Test	ISO 16750-2	Power supply at 18 V for 60 min.
Superimposed Alternating Voltage	ISO 16750-2	Test voltage U_c max 16 V for 12 V systems; ac voltage (sinusoidal): Severity 2, UPP = 4 V.
Slow Decrease/Increase of Supply Voltage	ISO 16750-2-4.5	Power supply changes from 18 V to 0 V / 0 V to 18 V with 0.5 V \pm 0.1 V step. At any step, power supply maintains 1 min. Product work well.
Reset Behavior at Voltage Drop	ISO16750-2-4.6.2.2	See Fig. 6
Transient Overvoltage Test	ISO16750-2	Power supply at 24 V for 10 min.
Momentary Drop in Supply Voltage	ISO 16750-2-4.6.1	U_{cmin} to 4.5 V. See Fig. 4
Load Dump	ISO 16750-2-4.6.4	Pulse described in Table 6. See Fig. 9
Reverse Voltage Test	ISO16750-2-4.7	Power supply at -24 V for 10 mins.
Single line Open Circuit Tests	ISO16750-2-4.9	Connect sensor to 12 V power supply and power on the sensor. Disconnect U_s , GND, CAN-H, and CAN-L in sequence. Each open circuit time :60 \pm 1 s
Short Circuit Protection	ISO 16750-2-4.10	Connect sensor to power supply and power on the sensor by 18 Vdc and 24 Vdc. Apply short circuit between CAN-H & GND, CAN-L & GND, CAN-H & U_s , CAN-L & U_s . Each hold for 60 seconds
dc Supply Voltage	ISO16750-2	Power supply at U_{cmin} 7 V and U_{cmax} 18 V
Insulation Resistance Test	ISO 16750-2-4.12	500 Vdc \pm 10 Vdc for 60 s; Resistance criteria: \geq 500 MOhm
dc & ac Voltage Insulation Test		Test Voltage: 5000 Vdc & ac. Frequency: dc & 50 Hz~60Hz. Test Duration: 60s

WARRANTY/REMEDY

Honeywell warrants goods of its manufacture as being free of defective materials and faulty workmanship during the applicable warranty period. Honeywell's standard product warranty applies unless agreed to otherwise by Honeywell in writing; please refer to your order acknowledgment or consult your local sales office for specific warranty details. If warranted goods are returned to Honeywell during the period of coverage, Honeywell will repair or replace, at its option, without charge those items that Honeywell, in its sole discretion, finds defective.

The foregoing is buyer's sole remedy and is in lieu of all other warranties, expressed or implied, including those of merchantability and fitness for a particular purpose. In no event shall Honeywell be liable for consequential, special, or indirect damages.

While Honeywell may provide application assistance personally, through our literature and the Honeywell web site, it is buyer's sole responsibility to determine the suitability of the product in the application.

Specifications may change without notice. The information we supply is believed to be accurate and reliable as of this writing. However, Honeywell assumes no responsibility for its use.

For more information

Honeywell Sensing & Safety Technologies services its customers through a worldwide network of sales offices and distributors. For application assistance, current specifications, pricing or the nearest Authorized Distributor, visit our [website](#) or call:

USA/Canada	+1 302 613 4491
Latin America	+1 305 805 8188
Europe	+44 1344 238258
Japan	+81 (0) 3-6730-7152
Singapore	+65 6355 2828
Greater China	+86 4006396841

Honeywell Sensing & Safety Technologies

830 East Arapaho Road
Richardson, TX 75081
www.honeywell.com

WARNING PERSONAL INJURY

DO NOT USE these products as safety or emergency stop devices or in any other application where failure of the product could result in personal injury.

Failure to comply with these instructions could result in death or serious injury.

WARNING MISUSE OF DOCUMENTATION

- The information presented in this product sheet is for reference only. Do not use this document as a product installation guide.
- Complete installation, operation, and maintenance information is provided in the instructions supplied with each product.

Failure to comply with these instructions could result in death or serious injury.